

C70793 RKP-D Pump Test Kit

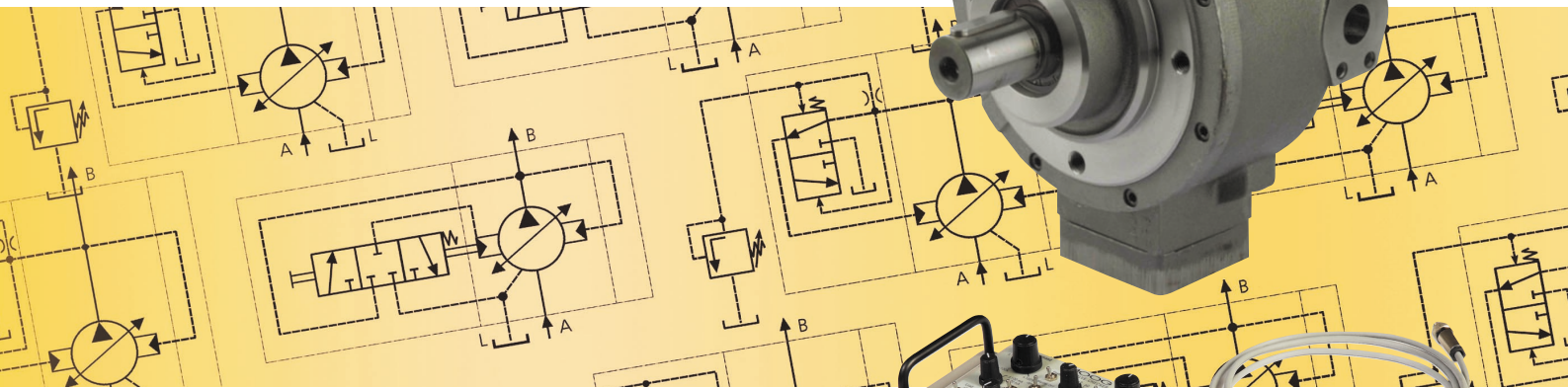
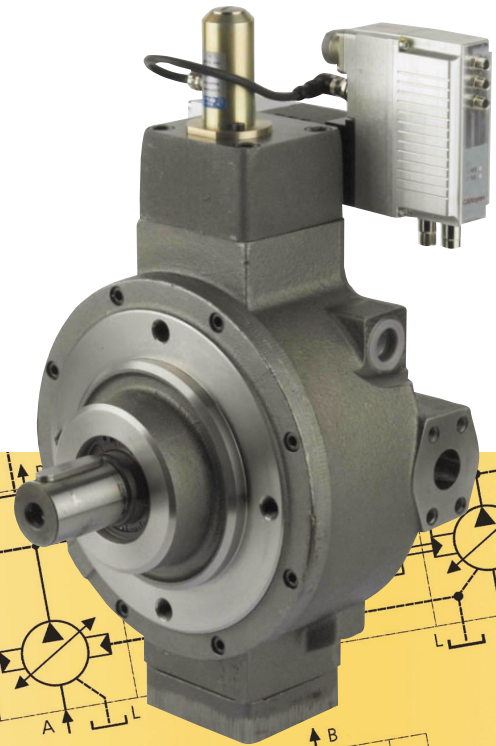

DESCRIPTION

The Moog RKP-D Pump Checker and Programmer Test Kit is intended for field testing and programming of the RKP-D Radial Piston Pump. This is achieved using the PQ Valve and Pump Checker, G040-125-001, for flow and pressure testing and the RKP-D Programmer, G040-127-000, for setting the control valve gain. They are contained in the C70793 kit but may be ordered separately.

The Moog PQ Valve and Pump Checker G040-125-001 and the RKP-D Programmer G040-127-001 are described separately in this data sheet.

PQ Valve and Pump Checker G040-125-001

DESCRIPTION

The Moog G040-125-001 PQ Valve and Pump Checker is a portable test instrument intended for field testing of servo and proportional valves and the RKP-D Pump. It provides quick and easy validation of Moog servo valve or pump performance. This enables hydraulic and electronic problems to be isolated, giving speedy and reliable system troubleshooting.

For valve testing refer to PQ valve checker data sheet located at <http://www.moog.com/valvetesters>

The RKP-D Valve and Pump Checker is configured for testing a pump by a small plug-in key. This obviates the need for many bulky and expensive cables, making the complete package small, inexpensive and easy to use.

There are two modes of operation:

- In-line mode, called "plant mode"; the Checker connects to the pump and plant electronics and monitors the electronic signals, in response to the plant electronic commands.
- Stand-alone mode, called "checker mode"; the Checker generates commands to the pump and monitors the pump's displacement and pressure signals.

Internal power is derived from the plant supply to the pump, or from an external 24V DC supply that connects to the rear panel of the Pump Checker.

FEATURES

- Enables setup with and without the need of a computer and MOVACO software
- Provides hydraulic test independent of plant electronics
- Enables system fault isolation to either hydraulics or electronics
- In-built LED spool/pressure meter
- Test points on all pump connector pins
- Can also be used to check Moog proportional and servo valves

SPECIFICATIONS

Q Command Outputs:	$\pm 10V$, $\pm 10mA$, $\pm 100mA$, 4-20mA, plant command
Q Command Test Point:	0 to $\pm 10V$
P Command Outputs:	0 to $+10V$, 0 to $+10mA$, 4-20mA, plant command
P Command Test Point:	0 to $+10V$
P&Q Commands Output Swing:	$\pm 10V$
Q (Spool) Feedback:	2.5 to 13.5V, $\pm 10V$ differential, $\pm 10V$ single ended, $\pm 10mA$, 4-20mA, 2-10V
Q (Spool) Feedback Test Point:	$\pm 10V$
P Feedback:	0 to $+10V$, 0 to $+10mA$, 4-20mA
P Feedback Test Point:	0 to $+10V$
Supply:	$\pm 15V$
	± 14.25 to $\pm 15.75V$, $\pm 80mA$ at $\pm 15V$, excluding valve
24V	22 to 28V, 140mA at 24V, excluding valve. 800mA at 24V and maximum $\pm 350mA$ from the internal $\pm 15V$ supply
Enable OK, Valve OK, and Safe Position threshold:	on at 8.5V off at 6.5V
Weight:	680gm
Dimensions:	190W x 140D x 70H
EMC:	EN61000-4-2, emission EN61000-6-2, immunity
Protective earth:	EN60204-1 equal-potential



RKP-D Programmer G040-127-001

DESCRIPTION

The Moog RKP-D Programmer is a portable test instrument intended for in-field Analog Programming of RKP-D Radial Piston Pumps and is used in conjunction with the PQ Valve and Pump Checker G040-125-001. It supplies an analog voltage from a selection of 16 values to enable parameter programming and is connected into one of the analog input ports of the RKP-D controller.

FEATURES

- Supplies an analog voltage from a selection of 16 values for parameter selection
- Compatible with PQ Valve and Pump Checker G040-125-001
- Lightweight and portable
- Built-in LED power supply connected LED (Vs)
- Test points on analog output voltage
- Reverse polarity protection

BENEFITS

- Plug in operation
- Simple operation
- Compatible with PQ Valve and Pump Checker G040-125-001
- Also enables pump setup with MOVACO software and CAN hardware

SPECIFICATIONS

12-24 Volt DC Input Supply is sourced via the screened 2.0 meter cable from the RKP-D.

Transition time between voltage steps is less than 1 ms.

Output voltage levels from 1.5 to 9 volts DC are kept stable with noise nominally less than +/- 50mV. This avoids spurious switching from one parameter set to the other.

Plug: RSMC4 Lumberg
Pin 1 Output Voltage
Pin 2 GND
Pin 3 GND
Pin 4 +24 Supply Input

Weight: 170 gm

Dimensions: W 102 mm x D 790 mm x H 51 mm

EMC: EN61000-4-2, emission
EN61000-6-2 immunity



ORDERING INFORMATION

- | | |
|-----------------|-----------------------------------|
| C70793 | Kit consisting of all items below |
| 1. G040-127-001 | RKP-D Programmer* |
| 2. G040-125-001 | PQ Valve and Pump Checker |
| 3. C70618-023 | Key* |
| 4. C70615-003 | Valve cable* |
| 5. C70616-003 | Plant cable* |

Options

- | | |
|------------|---|
| C31507-002 | External 24VDC power supply,
110 to 264 VAC, 50-60Hz |
|------------|---|

*If you already have a PQ Valve and Pump Checker then you will only need these items to complete your RKP-D Pump Test Kit.

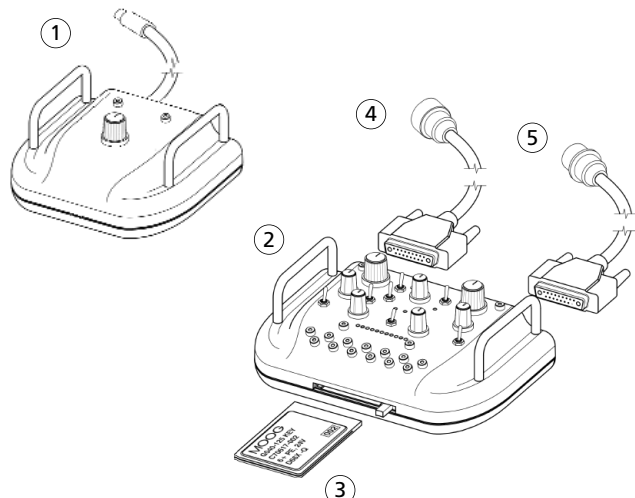

PQ Valve and Pump Checker

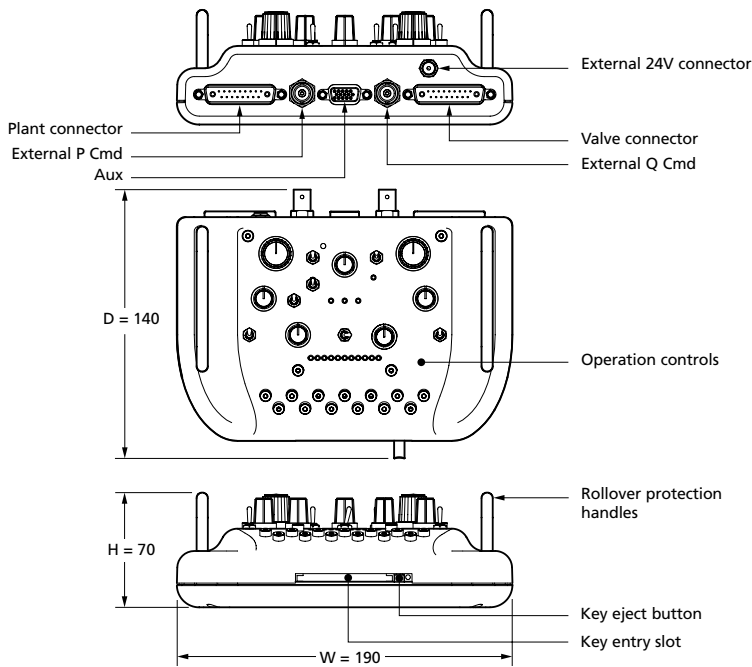

G040-125-001

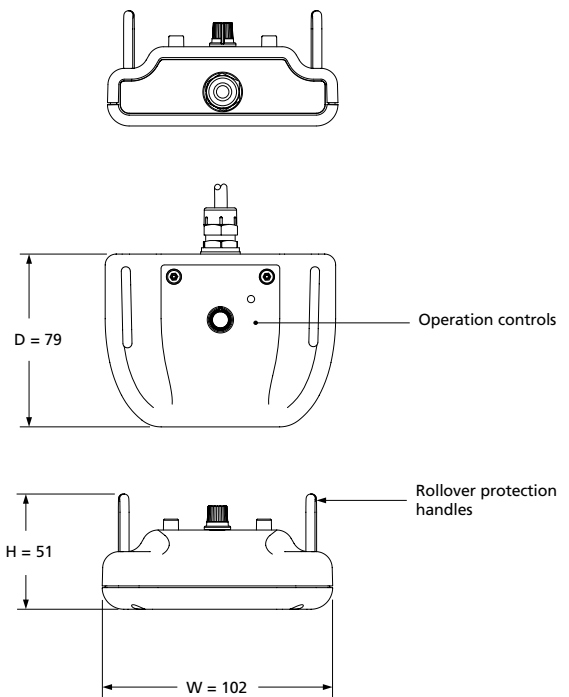

G040-127-001

INTERNET DATA

For the latest version of this Data Sheet, please refer to the Moog website www.moog.com/valvetesters

Moog Australia Pty Ltd • Australia +61-3-9561-6044 • USA +1-716-655-3000 • Germany +49-7031-622-0 • Japan +81-463-55-3615
For the location nearest you, contact www.moog.com/worldwide. For disclaimers, see www.moog.com/literature/disclaimers.